

SET – 3

Series : SSO/1/C

कोड नं.
Code No.

55/1/3

रोल नं.

--	--	--	--	--	--	--	--

Roll No.

परीक्षार्थी कोड को उत्तर-पुस्तिका के मुख-पृष्ठ पर अवश्य लिखें ।

Candidates must write the Code on the title page of the answer-book.

- कृपया जाँच कर लें कि इस प्रश्न-पत्र में मुद्रित पृष्ठ 12 हैं ।
- प्रश्न-पत्र में दाहिने हाथ की ओर दिए गए कोड नम्बर को छात्र उत्तर-पुस्तिका के मुख-पृष्ठ पर लिखें ।
- कृपया जाँच कर लें कि इस प्रश्न-पत्र में 26 प्रश्न हैं ।
- कृपया प्रश्न का उत्तर लिखना शुरू करने से पहले, प्रश्न का क्रमांक अवश्य लिखें ।
- इस प्रश्न-पत्र को पढ़ने के लिए 15 मिनट का समय दिया गया है । प्रश्न-पत्र का वितरण पूर्वाह्न में 10.15 बजे किया जायेगा । 10.15 बजे से 10.30 बजे तक छात्र केवल प्रश्न-पत्र को पढ़ेंगे और इस अवधि के दौरान वे उत्तर-पुस्तिका पर कोई उत्तर नहीं लिखेंगे ।
- Please check that this question paper contains 12 printed pages.
- Code number given on the right hand side of the question paper should be written on the title page of the answer-book by the candidate.
- Please check that this question paper contains 26 questions.
- **Please write down the Serial Number of the question before attempting it.**
- 15 minutes time has been allotted to read this question paper. The question paper will be distributed at 10.15 a.m. From 10.15 a.m. to 10.30 a.m., the students will read the question paper only and will not write any answer on the answer-book during this period.

भौतिक विज्ञान (सैद्धान्तिक)

PHYSICS (Theory)

निर्धारित समय : 3 घंटे]

[अधिकतम अंक : 70

Time allowed : 3 hours]

[Maximum Marks : 70

सामान्य निर्देश :

- (i) सभी प्रश्न अनिवार्य हैं । इस प्रश्न-पत्र में कुल 26 प्रश्न हैं ।
- (ii) इस प्रश्न-पत्र के 5 भाग हैं : खण्ड-अ, खण्ड-ब, खण्ड-स, खण्ड-द और खण्ड-य ।
- (iii) खण्ड-अ में 5 प्रश्न हैं, प्रत्येक का 1 अंक है । खण्ड-ब में 5 प्रश्न हैं, प्रत्येक के 2 अंक हैं । खण्ड-स में 12 प्रश्न हैं, प्रत्येक के 3 अंक हैं । खण्ड-द में 4 अंक का एक मूल्याधारित प्रश्न है और खण्ड-य में 3 प्रश्न हैं, प्रत्येक के 5 अंक हैं ।
- (iv) प्रश्न-पत्र में समग्र पर कोई विकल्प नहीं है । तथापि, दो अंकों वाले एक प्रश्न में, तीन अंकों वाले एक प्रश्न में और पाँच अंकों वाले तीनों प्रश्नों में आन्तरिक चयन प्रदान किया गया है । ऐसे प्रश्नों में आपको दिए गए चयन में से केवल एक प्रश्न ही करना है ।

55/1/3

1

[P.T.O.]



(v) जहाँ आवश्यक हो आप निम्नलिखित भौतिक नियतांकों के मानों का उपयोग कर सकते हैं :

$$c = 3 \times 10^8 \text{ m/s}$$

$$h = 6.63 \times 10^{-34} \text{ Js}$$

$$e = 1.6 \times 10^{-19} \text{ C}$$

$$\mu_0 = 4\pi \times 10^{-7} \text{ T m A}^{-1}$$

$$\epsilon_0 = 8.854 \times 10^{-12} \text{ C}^2 \text{ N}^{-1} \text{ m}^{-2}$$

$$\frac{1}{4\pi\epsilon_0} = 9 \times 10^9 \text{ N m}^2 \text{ C}^{-2}$$

$$m_e = 9.1 \times 10^{-31} \text{ kg}$$

$$\text{न्यूट्रॉन का द्रव्यमान} = 1.675 \times 10^{-27} \text{ kg}$$

$$\text{प्रोटॉन का द्रव्यमान} = 1.673 \times 10^{-27} \text{ kg}$$

$$\text{आवोगाद्रो संख्या} = 6.023 \times 10^{23} \text{ प्रति ग्राम मोल}$$

$$\text{बोल्ट्ज़मान नियतांक} = 1.38 \times 10^{-23} \text{ JK}^{-1}$$

General Instructions :

- (i) *All questions are compulsory. There are 26 questions in all.*
- (ii) *This question paper has five sections : Section A, Section B, Section C, Section D and Section E.*
- (iii) *Section A contains five questions of one mark each, Section B contains five questions of two marks each, Section C contains twelve questions of three marks each, Section D contains one value based question of four marks and Section E contains three questions of five marks each.*
- (iv) *There is no overall choice. However, an internal choice has been provided in one question of two marks, one question of three marks and all the three questions of five marks weightage. You have to attempt only one of the choices in such questions.*
- (v) *You may use the following values of physical constants wherever necessary :*

$$c = 3 \times 10^8 \text{ m/s}$$

$$h = 6.63 \times 10^{-34} \text{ Js}$$

$$e = 1.6 \times 10^{-19} \text{ C}$$

$$\mu_0 = 4\pi \times 10^{-7} \text{ T m A}^{-1}$$

$$\epsilon_0 = 8.854 \times 10^{-12} \text{ C}^2 \text{ N}^{-1} \text{ m}^{-2}$$

$$\frac{1}{4\pi\epsilon_0} = 9 \times 10^9 \text{ N m}^2 \text{ C}^{-2}$$

$$m_e = 9.1 \times 10^{-31} \text{ kg}$$

$$\text{Mass of neutron} = 1.675 \times 10^{-27} \text{ kg}$$

$$\text{Mass of proton} = 1.673 \times 10^{-27} \text{ kg}$$

$$\text{Avogadro's number} = 6.023 \times 10^{23} \text{ per gram mole}$$

$$\text{Boltzmann constant} = 1.38 \times 10^{-23} \text{ JK}^{-1}$$

खण्ड – अ

Section – A

1. इलेक्ट्रॉन की गतिज ऊर्जा के फलन के रूप में इसकी दे-ब्रोग्ली तरंगदैर्घ्य के विचरण को ग्राफ खींचकर दर्शाइए । 1

Draw a plot showing the variation of de Broglie wavelength of electron as a function of its K. E.

2. मोबाइल फोन में आगमी सिग्नलों और निर्गमी सिग्नलों की आवृत्तियाँ भिन्न क्यों होती है ? 1
Why is the frequency of outgoing and incoming signals different in a mobile phone ?

3. द्रव्यमान 'm' और आवेश 'q' का कोई कण 'v' वेग से किसी एकसमान चुम्बकीय क्षेत्र, जो कण की गति की दिशा के लम्बवत है, में प्रवेश करता है, उसकी गतिज ऊर्जा किस प्रकार प्रभावित होती है ? 1

A particle of mass 'm' and charge 'q' moving with velocity 'v' enters the region of uniform magnetic field at right angle to the direction of its motion. How does its kinetic energy get affected ?

4. चित्र में किसी धारावाही परिनालिका को किसी चालक लूप (पाश) की ओर गतिमान दर्शाया गया है । लूप में प्रेरित धारा की दिशा बताइए । 1

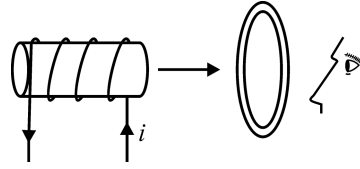
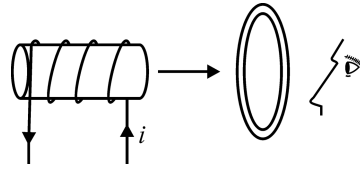

Figure shows a current carrying solenoid moving towards a conducting loop. Find the direction of the current induced in the loop.



5. जब किसी बिम्ब को किसी अवतल दर्पण के f और 2f के बीच रखा जाता है, तब बनने वाला प्रतिबिम्ब कैसा होता है – (i) वास्तविक अथवा आभासी और (ii) छोटा अथवा विवर्धित ? 1

When an object is placed between f and 2f of a concave mirror, would the image formed be (i) real or virtual and (ii) diminished or magnified ?



खण्ड – ब

Section – B

6. चित्र में दर्शाए गए निरोधी विभव और फोटॉन की आपतन आवृत्ति के बीच ग्राफ का उपयोग करके प्लांक नियतांक परिकलित कीजिए ।

2

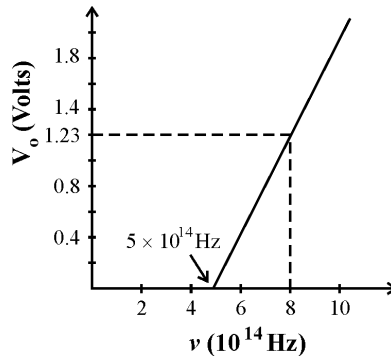

Using the graph shown in the figure for stopping potential V/s the incident frequency of photons, calculate Planck's constant.

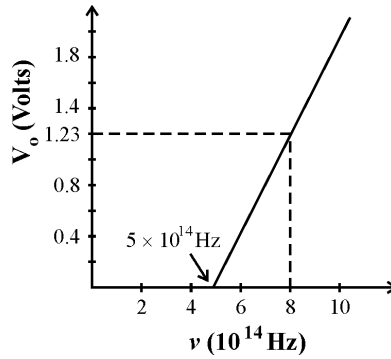

7. नीचे दी गयी नाभिकीय अभिक्रिया को पूरा कीजिए :

2

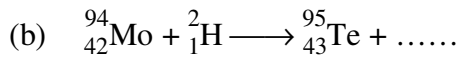
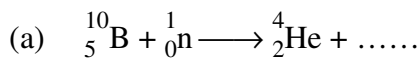

अथवा

यदि किसी नाभिकीय अभिक्रिया में प्रोटॉनों और न्यूट्रॉनों दोनों की संख्या संरक्षित रहती है, तब किस प्रकार द्रव्यमान का रूपान्तरण ऊर्जा में (अथवा इसका व्युत्क्रम) होता है ? एक उदाहरण सहित व्याख्या कीजिए ।

Complete the following nuclear reactions :

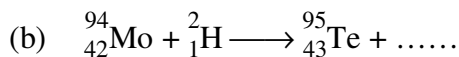
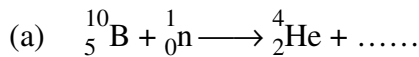

OR

If both the number of protons and neutrons in a nuclear reaction is conserved, in what way is mass converted into energy (or vice verse) ? Explain giving one example.

55/1/3

4

8. किसी चालक में आवेश वाहकों के अपवाह वेग की अवधारणा का उपयोग करके उस चालक की प्रतिरोधकता और धारा घनत्व के बीच संबंध व्युत्पन्न कीजिए । 2
Using the concept of drift velocity of charge carriers in a conductor, deduce the relationship between current density and resistivity of the conductor.
9. अध्रुवित प्रकाश और रेखिकतः ध्रुवित प्रकाश के बीच विभेदन कीजिए । आरेख की सहायता से वर्णन कीजिए कि किस प्रकार प्रकीर्णन द्वारा अध्रुवित प्रकाश रेखिकतः ध्रुवित हो जाता है । 2
Distinguish between unpolarised and a linearly polarised light. Describe, with the help of a diagram, how unpolarised light gets linearly polarised by scattering.
10. श्वेत प्रकाश किसी काँच के प्रिज़्म से गुजरने पर परिक्षेपित हो जाता है ।
लेंस मैकर सूत्र का उपयोग करके यह दर्शाइए कि किसी दिए गए लेंस की फोकस दूरी उस पर आपतित प्रकाश के वर्ण (रंग) पर निर्भर करती है । 2
Why does white light disperse when passed through a glass prism ?
Using lens maker's formula, show how the focal length of a given lens depends upon the colour of light incident on it.

खण्ड – स

Section – C

11. नीचे दिए गए प्रश्नों के उत्तर दीजिए : 3
- (i) समताप मण्डल के शीर्ष पर ओज़ोन की पतली परत मानव की उत्तरजीविता के लिए निर्णायक क्यों हैं ? वैद्युत-चुम्बकीय स्पेक्ट्रम के उस भाग की पहचान कीजिए जिससे यह विकिरण संबंधित है । इन विकिरणों का एक महत्वपूर्ण अनुप्रयोग लिखिए ।
- (ii) अवरक्त तरंगों को ऊष्मीय तरंगों क्यों माना जाता है ? ये किस प्रकार उत्पन्न होती हैं ? ग्रीन हाउस प्रभाव द्वारा पृथ्वी को उष्ण बनाए रखने में ये अपनी क्या भूमिका निभाती हैं ?
- Answer the following questions :
- (i) Why is the thin ozone layer on top of the stratosphere crucial for human survival ? Identify to which a part of electromagnetic spectrum does this radiation belong and write one important application of the radiation.
- (ii) Why are infrared waves referred to as heat waves ? How are they produced ? What role do they play in maintaining the earth's warmth through the greenhouse effect ?

12. माध्यमों के किसी युगल के लिए पद “क्रांतिक कोण” की परिभाषा लिखिए ।
15.0 cm त्रिज्या के किसी सिलिण्डर की तली के केन्द्र पर कोई एकवर्णी बिन्दु स्रोत ‘S’ रखा है । इस सिलिण्डर में 7.0 cm ऊँचाई तक जल (अपवर्तनांक 4/3) भरा है । प्रकाश किरण आरेख खींचिए और जल पृष्ठ का वह क्षेत्रफल परिकलित कीजिए जिससे प्रकाश वायु में निर्गत होगा । 3
Define the term ‘critical angle’ for a pair of media.
A point source of monochromatic light ‘S’ is kept at the centre of the bottom of a cylinder of radius 15.0 cm. The cylinder contains water (refractive index 4/3) to a height of 7.0 cm. Draw the ray diagram and calculate the area of water surface through which the light emerges in air.

13. नीचे दिए गए तीन लेंसों L_1 , L_2 और L_3 में से किन दो को आप सर्वोत्तम संभव (i) दूरदर्शक, (ii) सूक्ष्मदर्शी बनाने के लिए अभिदृश्यक और नेत्रिका के लिए चुनेंगे ?
अपने उत्तर की पुष्टि के लिए कारण दीजिए ।

लेंस	शक्ति (P)	द्वारक (A)
L_1	6D	1 cm
L_2	3D	8 cm
L_3	10D	1 cm

3

Which two of the following lenses L_1 , L_2 and L_3 will you select as objective and eyepiece for constructing best possible (i) telescope (ii) microscope ? Give reason to support your answer.

Lens	Power (P)	Aperture (A)
L_1	6D	1 cm
L_2	3D	8 cm
L_3	10D	1 cm

14. उपयुक्त आरेख खींचकर व्याख्या कीजिए कि द्विझिरी में व्यतिकरण पैटर्न वास्तव में, प्रत्येक झिरी के एकल झिरी विवर्तनों का अध्यारोपण ही है । इस व्यतिकरण पैटर्न और एकवर्णी स्रोत से प्रकाशित एकल झिरी में दिखाई देने वाले पैटर्न में विभेदन करने वाली दो मूल विशिष्टताएँ लिखिए ।

3

Explain by drawing a suitable diagram that the interference pattern in a double slit is actually a superposition of single slit diffraction from each slit.

Write two basic features which distinguish the interference pattern from those seen in a coherently illuminated single slit.

15. ऊर्जा-बैंड आरेखों के आधार पर n-प्रकार और p-प्रकार के अर्धचालकों के बीच विभेदन कीजिए । परम शून्य ताप और कक्ष ताप पर इनकी चालकताओं की तुलना कीजिए ।

3

Distinguish between n-type and p-type semi-conductors on the basis of energy band diagrams. Compare their conductivities at absolute zero temperature and at room temperature.

16. (a) किसी व्यापक संचार व्यवस्था का ब्लॉक-आरेख दिया गया है ।

3

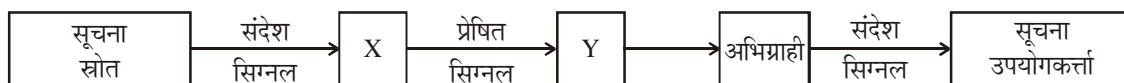

बॉक्स 'X' और 'Y' पहचानिए तथा इनके कार्य लिखिए ।

- (b) "बिन्दु से बिन्दु" और "प्रसारण" संचार के इन दो ढंगों में विभेदन कीजिए ।

- (a) Given a block diagram of a generalized communication system.

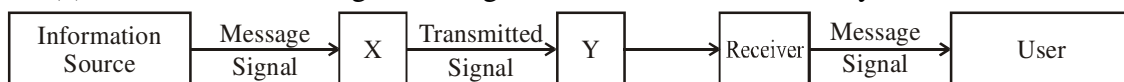

Identify the boxes 'X' and 'Y' and write their functions.

- (b) Distinguish between "Point to Point" and "Broadcast" modes of communication.

17. द्विध्रुव आघूर्ण \vec{p} के किसी वैद्युत द्विध्रुव को किसी एकसमान विद्युत क्षेत्र \vec{E} में रखा गया है। इस द्विध्रुव द्वारा अनुभव किए जाने वाले बल आघूर्ण $\vec{\tau}$ के लिए व्यंजक प्राप्त कीजिए। इस व्यंजक में लम्बवत सदिशों के दो युग्मों को पहचानिए।

3

An electric dipole of dipole moment \vec{p} is placed in a uniform electric field \vec{E} . Obtain the expression for the torque $\vec{\tau}$ experienced by the dipole. Identify two pairs of perpendicular vectors in the expression.

18. (a) R_1 और R_2 ($R_2 > R_1$) त्रिज्याओं के दो गोलीय चालकों को आवेशित किया गया है। यदि इन्हें किसी चालक तार से संयोजित किया जाता है, तो इनके पृष्ठीय आवेश घनत्वों का अनुपात ज्ञात कीजिए।
- (b) किसी असमान अनुप्रस्थ काट के धात्विक चालक से कोई स्थायी धारा प्रवाहित हो रही है। इस चालक के अनुदिश कौन सी राशि नियत है : विद्युत धारा, धारा घनत्व, विद्युत क्षेत्र, अपवाह चाल ?
- (a) Two spherical conductors of radii R_1 and R_2 ($R_2 > R_1$) are charged. If they are connected by a conducting wire, find out the ratio of the surface charge densities on them.
- (b) A steady current flows in a metallic conductor of non-uniform cross-section. Which of these quantities is constant along the conductor : current, current density, electric field, drift speed ?
19. चित्र में दर्शाए गए दो विद्युत परिपथों में आदर्श ऐमीटर (A) और आदर्श वोल्टमीटर (V) के पाठ्यांक निर्धारित कीजिए।

3

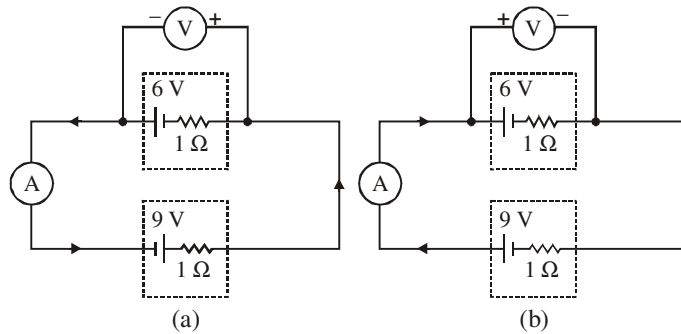

अथवा

चित्र में दर्शाए गए विद्युत परिपथ में प्रत्येक प्रतिरोधक से प्रवाहित धारा ज्ञात कीजिए।

3

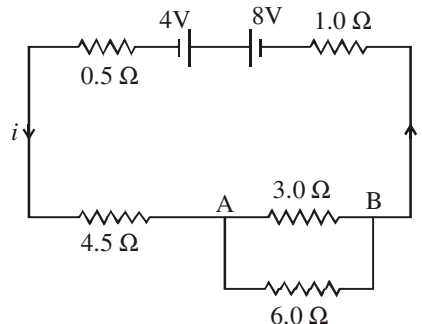

In the two electric circuits shown in the figure, determine the readings of ideal ammeter (A) and the ideal voltmeter (V).

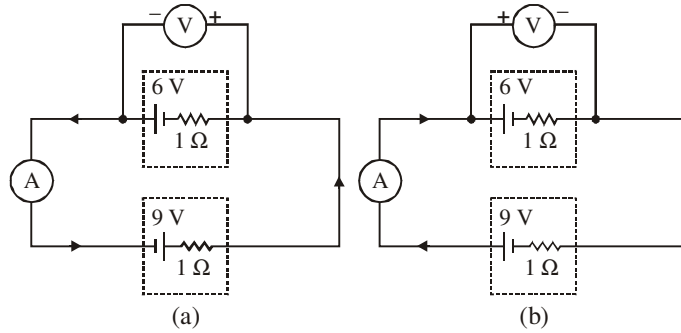

OR

In the circuit shown in the figure, find the current through each resistor.

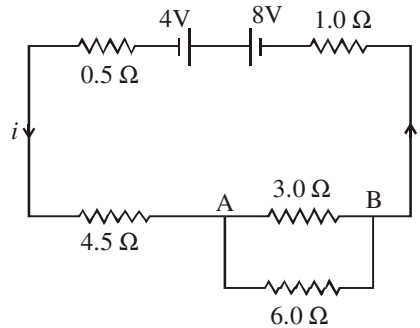

20. उपयुक्त आरेख की सहायता से (i) चुम्बकीय दिक्पात और (ii) नति कोण परिभाषित कीजिए । यदि किसी चुम्बकीय सुई को (i) ध्रुवों, (ii) विषुवत् वृत्त पर रखें, तो वह किस दिशा में संकेत करेगी ? 3

Define the following using suitable diagrams : (i) magnetic declination and (ii) angle of dip. In what direction will a compass needle point when kept at the (i) poles and (ii) equator ?

21. किसी परिनालिका जिसमें कोई स्थायी धारा I प्रवाहित हो रही है, में संचित चुम्बकीय ऊर्जा के लिए, परिनालिका के चुम्बकीय क्षेत्र B , क्षेत्रफल A तथा लम्बाई l के पदों में व्यंजक व्युत्पन्न कीजिए ।

प्रति एकांक आयतन इस चुम्बकीय ऊर्जा की तुलना किसी समान्तर पट्टिका संधारित्र में संचित स्थिर वैद्युत ऊर्जा घनत्व से किस प्रकार की जाती है ? 3

Derive the expression for the magnetic energy stored in a solenoid in terms of magnetic field B , area A and length l of the solenoid carrying a steady current I . How does this magnetic energy per unit volume compare with the electrostatic energy density stored in a parallel plate capacitor ?

22. किसी परिपथ में 80 mH के प्रेरक और 250 μF के संधारित्र को 240 V, 100 rad/s आपूर्ति से संयोजित किया गया है। परिपथ का प्रतिरोध उपेक्षणीय है।

- (i) धारा का rms मान प्राप्त कीजिए।
- (ii) परिपथ द्वारा अवशोषित कुल औसत शक्ति क्या है ?

3

A circuit containing an 80 mH inductor and a 250 μF capacitor in series connected to a 240 V, 100 rad/s supply. The resistance of the circuit is negligible.

- (i) Obtain rms value of current.
- (ii) What is the total average power consumed by the circuit ?

खण्ड – द

Section – D

23. अमीन को पिछले कुछ महीनों से विशाल राशि के विद्युत के बिल मिल रहे थे। इसके बारे में वह कुछ बेचैन था। एक दिन उसका मित्र रोहित, जो व्यवसाय से विद्युत अभियंता था, उसके घर आया। जब अमीन ने अपनी चिन्ता के बारे में रोहित को बताया, तो उसने यह पाया कि अमीन के घर में अभी भी तापदीप्त लैम्प और पुराने फैशन का एयरकन्डीशनर उपयोग किया जा रहा है। साथ ही घर में भू-सम्पर्कन भी उचित नहीं था। उसने अमीन से 1000 W – 220 V के सामान्य बल्ब के स्थान पर 28 W के CFL बल्बों का उपयोग करने और घर में उचित भू-सम्पर्कन कराने का परामर्श दिया। उसने और भी अन्य उपयोगी सुझाव दिए और इन संदेशों को अन्य मित्रों तक फैलाने का आग्रह किया।

- (i) आपके विचार से रोहित में कौन से गुण/मूल्य विद्यमान हैं ?
- (ii) पारम्परिक तापदीप्त लैम्पों की तुलना में CFL और LED क्यों बेहतर हैं ?
- (iii) भू-सम्पर्कन से विद्युत-बिल किस प्रकार से घट जाता है ?

4

Ameen had been getting huge electricity bill for the past few months. He was upset about this. One day his friend Rohit, an electrical engineer by profession, visited his house. When he pointed out his anxiety about this to Rohit, his friend found that Ameen was using traditional incandescent lamps and using old fashioned air conditioner. In addition there was no proper earthing in the house. Rohit advised him to use CFL bulbs of 28 W instead of 1000 W – 220 V and also advised him to get proper earthing in the house. He made some useful suggestion and asked him to spread this message to his friends also.

- (i) What qualities/values, in your opinion did Rohit possess ?
- (ii) Why CFLs and LEDs are better than traditional incandescent lamps ?
- (iii) In what way earthing reduces electricity bill ?

खण्ड – य

Section – E

24. (a) चित्र में किसी युक्ति 'X' द्वारा निवेशी तरंगरूप को निर्गत तरंगरूप में रूपान्तरित होता दर्शाया गया है। इस युक्ति का नाम लिखिए और उपयुक्त परिपथ द्वारा इसके कार्य की व्याख्या कीजिए। इसकी वोल्टता लब्धि और शक्ति लब्धि के लिए व्यंजक व्युत्पन्न कीजिए।

5

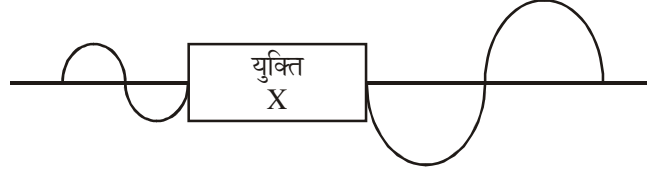

- (b) CE विन्यास में आधार बायसित ट्रांजिस्टर का अंतरण अभिलक्षण खींचिए। स्पष्ट रूप से व्याख्या कीजिए कि इस वक्र का कौन सा क्षेत्र प्रवर्धक के रूप में उपयोग किया जाता है।

अथवा

- (a) परिपथ आरेख की सहायता से किसी पूर्ण तरंग दिष्टकारी के कार्य की संक्षेप में व्याख्या कीजिए। इसके निवेशी और निर्गत तरंगरूप आलेखित कीजिए।
 (b) चित्र में दर्शाए गए परिपथ के तुल्य तर्क गेट पहचानिए। निवेश A और B के सभी संभव मानों के लिए सत्यमान सारणी खींचिए।

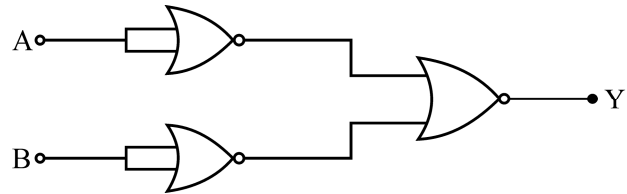

- (a) Figure shows the input waveform which is converted by a device 'X' into an output waveform. Name the device and explain its working using the proper circuit. Derive the expression for its voltage gain and power gain.

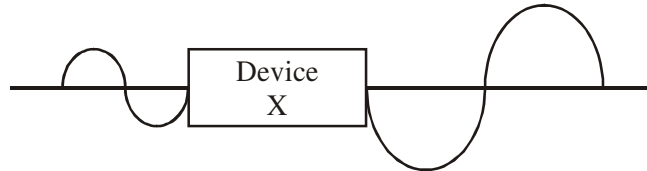

- (b) Draw the transfer characteristic of a base biased transistor in CE configuration. Explain clearly which region of the curve is used in an amplifier.

OR

- (a) Explain briefly, with the help of circuit diagram, the working of a full wave rectifier. Draw its input and output waveforms.
 (b) Identify the logic gate equivalent to the circuit shown in the figure. Draw the truth table for all possible values of inputs A and B.

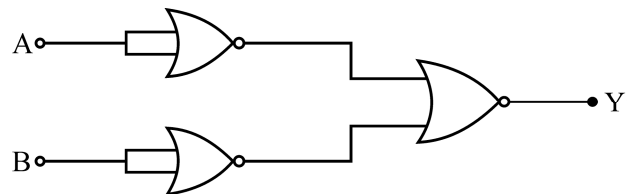

25. (a) सोने की पतली पन्नी द्वारा α कणों का प्रकीर्णन दर्शाने वाले गाइगर-मार्सडन प्रकीर्णन प्रयोग की योजनाबद्ध व्यवस्था का आरेख खींचिए । ऐसा क्यों है कि अधिकांश α -कण पन्नी से सीधे निकल गए और उनका थोड़ा भाग ही बड़े कोणों पर प्रकीर्णित हुआ ?

किसी नाभिक के कूलॉम-क्षेत्र में α -कणों के प्रक्षेप पथ खींचिए । संघट्ट प्राचल का क्या महत्त्व है और इससे नाभिक के साइज़ के विषय में क्या सूचना प्राप्त हो सकती है ?

- (b) 7.7 MeV के किसी α -कण की, नाभिक ($Z = 80$) से क्षणभर के लिए विरामावस्था में आने तथा दिशा प्रतिलोमन से पूर्व समीपस्थ दूरी का आकलन कीजिए ।

5

अथवा

- (a) रदरफोर्ड मॉडल की वह दो महत्त्वपूर्ण सीमाएँ लिखिए जो परमाण्वीय स्पेक्ट्रम की प्रेक्षित विशिष्टताओं की व्याख्या नहीं कर सकीं । बोर के हाइड्रोजन परमाणु के मॉडल द्वारा इनकी व्याख्या किस प्रकार की गयी ?

रिडबर्ग सूत्र का उपयोग करके H_α लाइन की तरंगदैर्घ्य का परिकलन कीजिए ।

($R = 1.1 \times 10^7 \text{ m}^{-1}$ लीजिए)

- (b) बोर के अभिगृहीतों का उपयोग करके हाइड्रोजन परमाणु की n वीं कक्षा की त्रिज्या के लिए व्यंजक प्राप्त कीजिए ।

- (a) Draw a schematic arrangement of Geiger-Marsden experiment showing the scattering of α -particles by a thin foil of gold. Why is it that most of the α -particles go right through the foil and only a small fraction gets scattered at large angles ?

Draw the trajectory of the α -particle in the coulomb field of a nucleus. What is the significance of impact parameter and what information can be obtained regarding the size of the nucleus ?

- (b) Estimate the distance of closest approach to the nucleus ($Z = 80$) if a 7.7 MeV α -particle before it comes momentarily to rest and reverses its direction.

OR

- (a) Write two important limitations of Rutherford model which could not explain the observed features of atomic spectra. How were these explained in Bohr's model of hydrogen atom ?

Use the Rydberg formula to calculate the wavelength of the H_α line.

(Take $R = 1.1 \times 10^7 \text{ m}^{-1}$).

- (b) Using Bohr's postulates, obtain the expression for the radius of the n^{th} orbit in hydrogen atom.

26. (a) बायो सावर्ट नियम का उपयोग करके त्रिज्या R और N फेरों की धारावाही वृत्ताकार कुण्डली के कारण कुण्डली के अक्ष पर कुण्डली के केन्द्र से 'x' दूरी पर स्थित किसी बिन्दु पर उत्पन्न चुम्बकीय क्षेत्र के लिए व्यंजक व्युत्पन्न कीजिए । इस कुण्डली के कारण उत्पन्न चुम्बकीय क्षेत्र रेखाओं को आरेखित कीजिए ।

- (b) चित्र में दर्शाए अनुसार 'R' त्रिज्या के किसी एकसमान वृत्ताकार लूप (पाश) में कोई धारा 'I' बिन्दु M से प्रवेश करके N से बाहर निकलती है । लूप के केन्द्र पर नेट चुम्बकीय क्षेत्र प्राप्त कीजिए ।

5

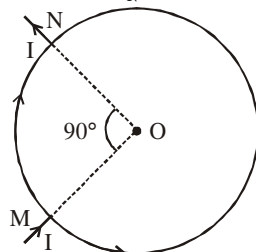

अथवा

55/1/3

11

[P.T.O.]

- (a) यह दर्शाइए कि बायो सावर्ट नियम को वैकल्पिक रूप से ऐम्पियर परिपथीय नियम के रूप में किस प्रकार व्यक्त किया जा सकता है। इस नियम का उपयोग करके लम्बाई ' l ' अनुप्रस्थ-काट क्षेत्रफल ' A ' कसकर पास-पास लिपटे ' N ' फेरों की परिनालिका, जिससे स्थायी धारा ' I ' प्रवाहित हो रही है, के भीतर उत्पन्न चुम्बकीय क्षेत्र के लिए व्यंजक प्राप्त कीजिए।

किसी परिमित परिनालिका, जिससे धारा ' I ' प्रवाहित हो रही है, की चुम्बकीय क्षेत्र रेखाएँ आरेखित कीजिए।

- (b) लम्बाई 0.45 m और द्रव्यमान 60 g की कोई सीधी क्षैतिज चालक छड़ इसके दोनों सिरों पर लगे दो ऊर्ध्वाधर तारों द्वारा निलम्बित है। तारों से होकर इस छड़ से 5.0 A की स्थायी धारा प्रवाहित हो रही है। उस चुम्बकीय क्षेत्र का परिमाण और दिशा ज्ञात कीजिए जिसे उत्पन्न करने पर तारों में तनाव शून्य हो जाए।

- (a) Use Biot-Savart law to derive the expression for the magnetic field due to a circular coil of radius R having N turns at a point on the axis at a distance ' x ' from its centre.

Draw the magnetic field lines due to this coil.

- (b) A current ' I ' enters a uniform circular loop of radius ' R ' at point M and flows out at N as shown in the figure.

Obtain the net magnetic field at the centre of the loop

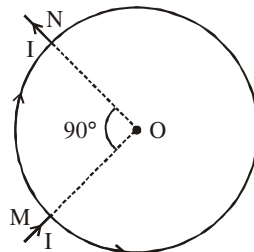

OR

- (a) Show how Biot-Savart law can be alternatively expressed in the form of Ampere's circuital law. Use this law to obtain the expression for the magnetic field inside a solenoid of length ' l ', cross-sectional area ' A ' having ' N ' closely wound turn and carrying a steady current ' I '.

Draw the magnetic field lines of a finite solenoid carrying current I .

- (b) A straight horizontal conducting rod of length 0.45 m and mass 60 g is suspended by two vertical wires at its ends. A current of 5.0 A is set up in the rod through the wires.

Find the magnitude and direction of the magnetic field which should be set up in order that the tension in the wire is zero.

MARKING SCHEME
SET 55/1/1 (Compartment)

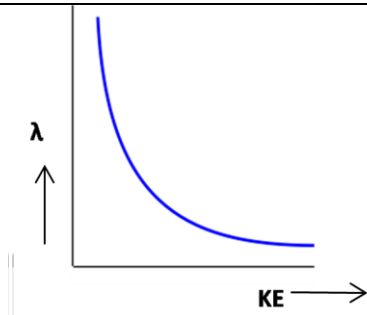
Q. No.	Expected Answer / Value Points	Marks	Total Marks
Section A			
Set1,Q1 Set2,Q4 Set3,Q3	Kinetic energy will not be affected.	1	1
Set1,Q2 Set2,Q5 Set3,Q4	Clockwise on the side of the observer. [Alternatively :The candidate who draws diagram with arrow indicating the direction correctly, may also be given full credit.]	1	1
Set1,Q3 Set2,Q1 Set3,Q5	(i) Real (ii) magnified	½ + ½	1
Set1,Q4 Set2,Q2 Set3,Q1		1	1
Set1,Q5 Set2,Q3 Set3,Q2	To avoid overlapping of the two signals	1	1
Section B			
Set1,Q6 Set2,Q10 Set3,Q8	<div style="border: 1px solid black; padding: 5px; margin-bottom: 10px;"> Derivation of Relationship between current density and resistivity 2 </div> <p>Drift velocity $v_d = \frac{eE}{m} \tau$ (τ = relaxation time)</p> <p>The current $I = neA v_d$ (n = number of charge carriers per unit volume.) $= j A$</p> $j = \frac{ne^2}{m} \tau E$ $j = \frac{1}{\rho} E$	½ ½ ½ ½	2
Set1,Q7 Set2,Q6 Set3,Q9	<div style="border: 1px solid black; padding: 5px; margin-bottom: 10px;"> Unpolarised light and linearly polarized light ½ + ½ Diagram & description ½ + ½ </div> <p>For unpolarised light electric vector associated with light, is oscillating randomly in all directions in a plane perpendicular to the direction of propagation of light.</p> <p>In linearly polarised light oscillating electric vector gets aligned along one direction perpendicular to the direction of propagation of light.</p>	½ ½	

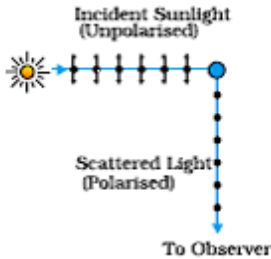
	<p>[Under the influence of the electric field of the incident wave, the electrons (of the scattering molecules), accelerated parallel to the double arrows, do not radiate energy towards the observer. Hence, the scattered light gets polarized.]</p> 	1/2 + 1/2	2				
Set1,Q8 Set2,Q7 Set3,Q10	<table border="1" data-bbox="256 481 1246 584"> <tr> <td>Reason for dispersion</td> <td>1</td> </tr> <tr> <td>Dependence of focal length of the lens on colour</td> <td>1</td> </tr> </table> <p>The refractive index of the glass of the prism is different for different wavelengths(colours). Hence, different colours get bent along different directions. Using lens maker's formula $\frac{1}{f} = (n_{21} - 1) \left(\frac{1}{R_1} - \frac{1}{R_2} \right), n_{21} = \frac{n_2}{n_1}$ As the refractive index of the medium with respect to air (medium 1) depends on the wavelength or colour of light, focal length of the lens would change with colour.</p>	Reason for dispersion	1	Dependence of focal length of the lens on colour	1	1 1	2
Reason for dispersion	1						
Dependence of focal length of the lens on colour	1						
Set1,Q9 Set2,Q8 Set3,Q6	<table border="1" data-bbox="256 958 1246 1032"> <tr> <td>Calculation of the value of Plank's constant</td> <td>2</td> </tr> </table> <p>According to Einstein's photoelectric equation</p> $V_o = \frac{h}{e} \nu - \frac{\phi_o}{e}$ <p>In the given graph: Stopping potential $V_o = 1.23 \text{ V}$ Change in frequency $\Delta\nu = 3 \times 10^{14} \text{ Hz}$ (Alternatively : slope of the line = $\frac{h}{e}$)</p> $\frac{h}{e} = \frac{V_o}{\Delta\nu} = \frac{1.23}{3 \times 10^{14}}$ $\therefore h = \frac{1.23 \times 1.6 \times 10^{-19}}{3 \times 10^{14}} \text{ J-s}$ $= 6.6 \times 10^{-34} \text{ J-s}$	Calculation of the value of Plank's constant	2	1/2 1/2 1/2	2		
Calculation of the value of Plank's constant	2						
Set1,Q10 Set2,Q9 Set3,Q7	<table border="1" data-bbox="256 1574 1246 1680"> <tr> <td>Completion of nuclear reaction (a)</td> <td>1</td> </tr> <tr> <td>Completion of nuclear reaction (b)</td> <td>1</td> </tr> </table> <p>(a) ${}_{5}^{10}\text{B} + {}_0^1\text{n} \rightarrow {}_2^4\text{He} + {}_3^7\text{Li}$ (b) ${}_{42}^{94}\text{MO} + {}_1^2\text{H} \rightarrow {}_{43}^{95}\text{Te} + {}_0^1\text{n}$</p> <p>[Note: For reaction (a) even if the candidate writes ${}^7_3\text{X}$, award 1 mark]</p> <p style="text-align: center;">OR</p>	Completion of nuclear reaction (a)	1	Completion of nuclear reaction (b)	1	1 1	
Completion of nuclear reaction (a)	1						
Completion of nuclear reaction (b)	1						



	<table border="1" style="width: 100%;"> <tr> <td style="width: 70%;">Explanation of conversion of mass into energy (vice versa)</td> <td style="width: 30%; text-align: right;">1</td> </tr> <tr> <td>Example</td> <td style="text-align: right;">1</td> </tr> </table> <p>Since proton number and neutron number are conserved, the total rest mass of neutron and protons is the same on either side of the nuclear reaction. But total binding energy of nuclei on the left side need not be the same as that on the right hand side. The difference in binding energy causes a release of energy in the reaction.</p> <p>Example :</p> ${}^2_1\text{H} + {}^2_1\text{H} \rightarrow {}^3_2\text{He} + {}^1_0n + \text{energy}$ <p>Or</p> $({}^{235}_{92}\text{U} + {}^1_0n \rightarrow {}^{144}_{56}\text{Ba} + {}^{89}_{36}\text{Kr} + 3{}^1_0n + \text{energy})$ <p>(Give full credit for any other one correct example.)</p>	Explanation of conversion of mass into energy (vice versa)	1	Example	1	1 1	2
Explanation of conversion of mass into energy (vice versa)	1						
Example	1						

Section C

<p>Set1,Q11 Set2,Q20 Set3,Q17</p>	<table border="1" style="width: 100%;"> <tr> <td style="width: 70%;">(i) Figure</td> <td style="width: 30%; text-align: right;">1/2</td> </tr> <tr> <td>(ii) Derivation of torque</td> <td style="text-align: right;">1 1/2</td> </tr> <tr> <td>(iii) Identification of two pairs</td> <td style="text-align: right;">1/2 + 1/2</td> </tr> </table> <div style="text-align: center; margin: 10px 0;"> </div> <p>The force on charge +q is $+q\vec{E}$ and on charge -q is $-q\vec{E}$. These, two parallel forces, acting in the opposite direction, constitute a couple resulting in the torque τ.</p> <p>Magnitude of torque = $qE \times 2a \sin \theta$ $= 2qa E \sin \theta$</p> <p>Therefore, $\vec{\tau} = \vec{p} \times \vec{E}$ where $\vec{p} = 2q\vec{a}$</p> <p>(ii) Two pairs of perpendicular vectors: (i) $\vec{\tau}$ is perpendicular to \vec{p} (ii) $\vec{\tau}$ is perpendicular to \vec{E}</p>	(i) Figure	1/2	(ii) Derivation of torque	1 1/2	(iii) Identification of two pairs	1/2 + 1/2	1/2 1/2 1/2 1/2 1/2	3
(i) Figure	1/2								
(ii) Derivation of torque	1 1/2								
(iii) Identification of two pairs	1/2 + 1/2								

<p>Set1,Q12 Set2,Q21 Set3,Q18</p>	<table border="1" style="width: 100%;"> <tr> <td style="width: 70%;">(a) Ratio of surface charge densities</td> <td style="width: 30%; text-align: right;">2</td> </tr> <tr> <td>(b) Identifying the constant quantity</td> <td style="text-align: right;">1</td> </tr> </table> <p>We have, $V = \frac{q_1}{c_1} = \frac{q_2}{c_2}$</p>	(a) Ratio of surface charge densities	2	(b) Identifying the constant quantity	1	1/2	
(a) Ratio of surface charge densities	2						
(b) Identifying the constant quantity	1						

	$\frac{q_1}{4\pi\epsilon_0 R_1} = \frac{q_2}{4\pi\epsilon_0 R_2} \Rightarrow \frac{q_1}{R_1} = \frac{q_2}{R_2}$ $\frac{\sigma_1}{\sigma_2} = \frac{q_1}{4\pi\epsilon_0 R_1^2} \times \frac{4\pi\epsilon_0 R_2^2}{q_2}$ $= \frac{q_1}{q_2} \times \frac{R_2^2}{R_1^2}$ $= \frac{R_1}{R_2} \times \frac{R_2^2}{R_1^2} = \frac{R_2}{R_1}$	<p>1/2</p> <p>1/2</p> <p>1/2</p> <p>1</p>	3
<p>Set1,Q13 Set2,Q22 Set3,Q19</p>	<p>Readings of ideal ammeter and ideal voltmeter in fig (a) and (b) 1 1/2 + 1 1/2</p> <p>In circuit (a) Total emf=15 V Total Resistance = 2Ω Current i= (15/2)A = 7.5 A Potential Difference between the terminals of 6 V battery V=E-iR =[6-(7.5×1)]V =-1.5 V</p> <p>In circuit (b)</p> <p>Effective emf=(9-6) V =3V Current i=(3/2)A=1.5 A Potential Difference across 6V cell V=E+iR =6+1.5×1 =7.5 V</p> <p style="text-align: center;">OR</p> <p>Finding current through each resistor 3</p> <p>Total emf in the circuit = 8V – 4V = 4V Total resistance of the circuit = 8Ω Hence current flowing in the circuit $i = \frac{V}{R} = \frac{4}{8} \text{ A} = 0.5 \text{ A}$ Current flowing through the resistors: Current through 0.5Ω, 1.0Ω and 4.5Ω is 0.5 A Current through 3.0Ω is $\frac{1}{3}$ A Current through 6.0Ω is $\frac{1}{6}$ A</p>	<p>1/2</p> <p>1/2</p> <p>1</p> <p>1/2</p> <p>1</p> <p>1/2</p> <p>1/2</p> <p>1/2</p> <p>1/2</p>	3

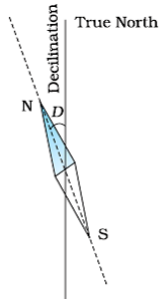
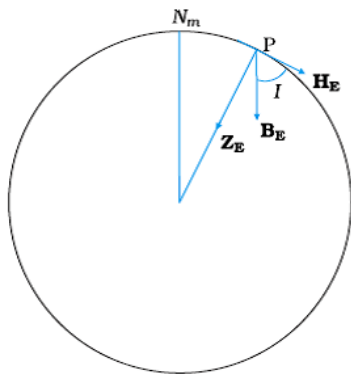

Set1,Q14 Set2,Q11 Set3,Q20	<p>Definition of</p> <p>(i) Magnetic declination and diagram $\frac{1}{2} + \frac{1}{2}$</p> <p>(ii) Angle of dip and diagram $\frac{1}{2} + \frac{1}{2}$</p> <p>Direction of compass needle at the</p> <p>(i) Poles $\frac{1}{2}$</p> <p>(ii) Equator $\frac{1}{2}$</p> <p>Magnetic declination : Angle between the magnetic axis and geographical axis.</p> <p>Alternatively: Angle between magnetic meridian and geographical meridian.</p>  <p>Angle of dip: It is the angle which the magnetic needle makes with the horizontal in the magnetic meridian.</p> <p>Alternatively: The angle which the total magnetic field of the earth makes with the surface of the earth.</p>  <p>Direction of compass needle is vertical to the earth's surface at poles and is parallel to the earth's surface at equator.</p>	<p>$\frac{1}{2}$</p> <p>$\frac{1}{2}$</p> <p>$\frac{1}{2}$</p> <p>$\frac{1}{2}$</p> <p>$\frac{1}{2} + \frac{1}{2}$</p>	<p>3</p>				
Set1,Q15 Set2,Q12 Set3,Q21	<table border="1" data-bbox="252 1462 1238 1599"> <tbody> <tr> <td>Derivation of magnetic energy</td> <td>2</td> </tr> <tr> <td>Comparison of magnetic energy per unit volume with Electrostatic energy density</td> <td>1</td> </tr> </tbody> </table> <p>Rate of work done</p> $\frac{dW}{dt} = \varepsilon I$ $= \left(LI \frac{dI}{dt} \right)$ $dW = LI dI$ <p>Total amount of work done</p> $\int dW = \int LI dI$ $W = \frac{1}{2} LI^2$	Derivation of magnetic energy	2	Comparison of magnetic energy per unit volume with Electrostatic energy density	1	<p>$\frac{1}{2}$</p> <p>$\frac{1}{2}$</p>	
Derivation of magnetic energy	2						
Comparison of magnetic energy per unit volume with Electrostatic energy density	1						

	<p>For the solenoid :</p> <p>Inductance, $L = \mu_0 n^2 A \ell$; also $B = \mu_0 n I$</p> <p>$\therefore W = U_B = \frac{1}{2} L I^2$</p> $\frac{1}{2} (\mu_0 n^2 A \ell) \left(\frac{B}{\mu_0 n} \right)^2$ $= \frac{B^2 A \ell}{2 \mu_0}$ <p>\Rightarrow Magnetic energy per unit volume $= \frac{B^2}{2 \mu_0}$</p> <p>Also, Electrostatic energy stored per unit volume $= \frac{1}{2} \epsilon_0 E^2$</p>	<p>1/2</p> <p>1/2</p> <p>1/2</p> <p>1/2</p>	<p>3</p>				
<p>Set1,Q16 Set2,Q13 Set3,Q22</p>	<table border="1" style="width: 100%; border-collapse: collapse;"> <tr> <td style="padding: 5px;">(i) Calculation of rms value of current</td> <td style="text-align: right; padding: 5px;">2</td> </tr> <tr> <td style="padding: 5px;">(ii) Calculation of total average power consumed.</td> <td style="text-align: right; padding: 5px;">1</td> </tr> </table> <p>(i) $X_L = \omega L = 100 \times 80 \times 10^{-3} = 8 \Omega$</p> $X_C = \frac{1}{\omega C} = \frac{1}{100 \times 250 \times 10^{-6}} \Omega$ $= 40 \Omega$ <p>Total Impedence (Z) $= X_C - X_L$ $= 32 \Omega$</p> $I_{rms} = \frac{240}{32} \text{ A} = 7.5 \text{ A}$ <p>(ii) Average power consumed = 0 (As there is no ohmic resistance in the current.)</p>	(i) Calculation of rms value of current	2	(ii) Calculation of total average power consumed.	1	<p>1/2</p> <p>1/2</p> <p>1/2</p> <p>1/2</p> <p>1</p>	<p>3</p>
(i) Calculation of rms value of current	2						
(ii) Calculation of total average power consumed.	1						
<p>Set1,Q17 Set2,Q14 Set3,Q11</p>	<table border="1" style="width: 100%; border-collapse: collapse;"> <tr> <td style="padding: 5px;">Answers of part (i) and (ii)</td> <td style="text-align: right; padding: 5px;">1 1/2 + 1 1/2</td> </tr> </table> <p>(i) It absorbs ultraviolet radiations from sun and prevents them from reaching on the earth's surface causing damage to life.</p> <p>Identification : ultraviolet radiations</p> <p>one correct application (=sanitization, forensics)</p> <p>(ii) Water molecules present in most materials readily absorbs infra red waves. Hence, their thermal motion increases. Therefore, they heat their surroundings.</p> <p>They are produced by hot bodies and molecules.</p> <p>Incoming visible light is absorbed by earth's surface and radiated as infra red radiations. These radiation are trapped by green house gases.</p>	Answers of part (i) and (ii)	1 1/2 + 1 1/2	<p>1/2</p> <p>1/2</p> <p>1/2</p> <p>1/2</p> <p>1/2</p> <p>1/2</p>	<p>3</p>		
Answers of part (i) and (ii)	1 1/2 + 1 1/2						

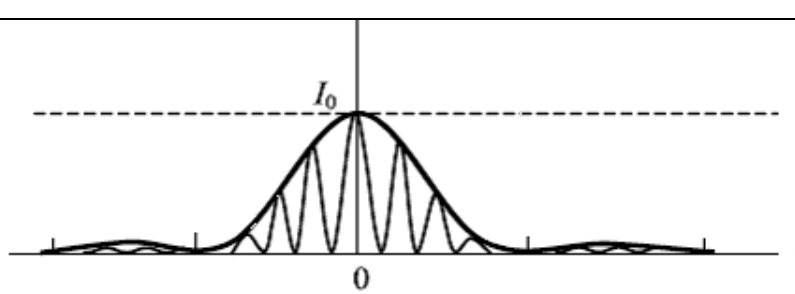
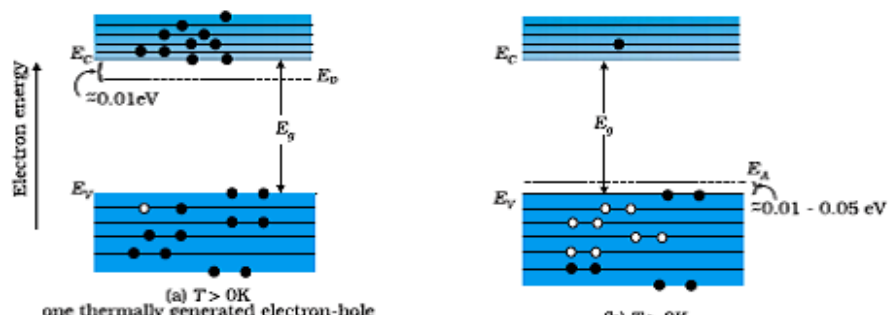
<p>Set1,Q20 Set2,Q17 Set3,Q14</p>	<p>Explanation by drawing a suitable diagram 1 Two basic features distinguishing interference pattern from diffraction pattern 1+1</p> <div style="text-align: center;">  </div> <p>The diagram, given here, shows several fringes, due to double slit interference, 'contained' in a broad diffraction peak. When the separation between the slits is large compared to their width, the diffraction pattern becomes very flat and we observe the two slit interference pattern.</p> <p>[Note: The students may be awarded 1 mark even if they just draw the diagram.]</p> <p>Two basic features:</p> <ol style="list-style-type: none"> (i) The interference pattern has a number of equally spaced bright and dark bands while diffraction pattern has a central bright maximum which is twice as wide as the other maxima. (ii) Interference pattern is the superimposition of two waves slits originating from two narrow sects. The diffraction pattern is a superposition of a continuous family of waves originating from each point on a single slit. (iii) For a single slit of width 'a' the first null of diffraction pattern occurs at an angle of $\frac{\lambda}{a}$. At the same angle of λ/a, we get a maxima for two narrow slits separated by a distance a. <p>[Any two of the above distinguishing features.]</p>	<p style="text-align: center;">1/2</p> <p style="text-align: center;">1/2</p> <p style="text-align: center;">1</p> <p style="text-align: center;">1</p>	<p style="text-align: center;">3</p>
<p>Set1,Q21 Set2,Q18 Set3,Q15</p>	<p>Distinction between n – type and p-type semi conductors on the basis of Energy band diagrams 2 Comparison of conductivities 1</p> <div style="text-align: center;">  </div> <ol style="list-style-type: none"> (i) In n - type semi conductors an extra energy level (called donor energy level) is produced just below the bottom of the conduction band, while in the p-type ssemiconductor, this extra energy band (called acceptor energy level) is just above the top of the balance band. (ii) In n – type semiconductors, most of the electrons come from the donor impurity while in p-type semi conductor, the density of holes in 	<p style="text-align: center;">1/2</p> <p style="text-align: center;">1/2</p> <p style="text-align: center;">1</p>	

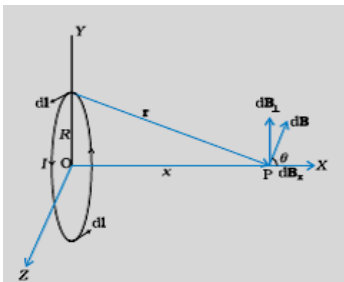
	<p>the valence band is predominantly due to the impurity in the extrinsic semiconductors.</p> <p>[Any one of the above, or any one, other, correct distinguishing feature.]</p> <p>At absolute zero temperature conductivities of both type of semi-conductors will be zero.</p> <p>For equal doping, an n-type semi conductor will have more conductivity than a p-type semiconductor, at room temperature.</p>	<p>1/2</p> <p>1/2</p>	<p>3</p>									
<p>Set1,Q22 Set2,Q19 Set3,Q16</p>	<table border="1" style="width: 100%;"> <tr> <td style="width: 10%;">(a)</td> <td style="width: 50%;">Identification of X and Y Their functions</td> <td style="width: 40%; text-align: right;">1/2 + 1/2 1/2 + 1/2</td> </tr> <tr> <td>(b)</td> <td>Distinction between point to point and broadcast mode.</td> <td style="text-align: right;">1</td> </tr> </table> <p>(a) X : Transmitter Y: Channel</p> <p>Their functions: Transmitter : To convert the message signal into suitable form for transmission through channel. Channel : It sends the signal to the receiver.</p> <p>(b) In point to point mode, communication takes place between a single transmitter and receiver. In broadcast mode, large number of receivers are connected to a single transmitter.</p>	(a)	Identification of X and Y Their functions	1/2 + 1/2 1/2 + 1/2	(b)	Distinction between point to point and broadcast mode.	1	<p>1/2</p> <p>1/2</p> <p>1/2</p> <p>1/2</p> <p>1</p>	<p>3</p>			
(a)	Identification of X and Y Their functions	1/2 + 1/2 1/2 + 1/2										
(b)	Distinction between point to point and broadcast mode.	1										
Section D												
<p>Set1,Q23 Set2,Q23 Set3,Q23</p>	<table border="1" style="width: 100%;"> <tr> <td style="width: 10%;">(i)</td> <td style="width: 50%;">Qualities / values of Rohit.</td> <td style="width: 40%; text-align: right;">1</td> </tr> <tr> <td>(ii)</td> <td>Advantage of CFLs/ LEDs over traditional incandescent lamps.</td> <td style="text-align: right;">1</td> </tr> <tr> <td>(iii)</td> <td>Role of earthing in reduction of electricity bills</td> <td style="text-align: right;">1</td> </tr> </table> <p>(i) Co-operative attitude and scientific temperament. (or any other two correct values.)</p> <p>(ii) a) Low operational voltage and less power. b) fast action and no warm up time required. (Any one)</p> <p>(iii) In the absence of proper earthing, the consumer can get (extra) charges for the electrical energy NOT consumed by the devices in her/his premises.</p>	(i)	Qualities / values of Rohit.	1	(ii)	Advantage of CFLs/ LEDs over traditional incandescent lamps.	1	(iii)	Role of earthing in reduction of electricity bills	1	<p>1+ 1</p> <p>1</p> <p>1</p>	<p>4</p>
(i)	Qualities / values of Rohit.	1										
(ii)	Advantage of CFLs/ LEDs over traditional incandescent lamps.	1										
(iii)	Role of earthing in reduction of electricity bills	1										
Section E												
<p>Set1,Q24 Set2,Q26 Set3,Q26</p>	<table border="1" style="width: 100%;"> <tr> <td style="width: 10%;">(a)</td> <td style="width: 50%;">Derivation of the expression</td> <td style="width: 40%; text-align: right;">2</td> </tr> <tr> <td>(b)</td> <td>Magnetic field lines due to the coil</td> <td style="text-align: right;">1</td> </tr> <tr> <td>(c)</td> <td>Magnetic field at the center of the loop</td> <td style="text-align: right;">2</td> </tr> </table> <p>(a)</p> 	(a)	Derivation of the expression	2	(b)	Magnetic field lines due to the coil	1	(c)	Magnetic field at the center of the loop	2	<p>1/2</p>	
(a)	Derivation of the expression	2										
(b)	Magnetic field lines due to the coil	1										
(c)	Magnetic field at the center of the loop	2										

According to Biot- Savart law,

$$d\vec{B} = \frac{\mu_0 I (d\vec{l} \times \vec{r})}{4\pi r^3}$$

$$dB = \frac{\mu_0 I dl}{4\pi (x^2 + R^2)} \quad \left[\begin{array}{l} \because |d\vec{l} \times \vec{r}| = r dl; \\ r = (x^2 + R^2)^{\frac{1}{2}} \end{array} \right]$$

From figure

$$\cos \theta = \frac{R}{(x^2 + R^2)^{\frac{1}{2}}}$$

\therefore Net contribution along x-direction

$$B = \sum dB \cos \theta = \int dB \cos \theta$$

$$= \int_0^{2\pi R} \frac{\mu_0 I dl}{4\pi} \frac{R}{(x^2 + R^2)^{\frac{3}{2}}}$$

$$\vec{B} = \frac{\mu_0 IR^2}{2(R^2 + x^2)^{\frac{3}{2}}} \hat{i}$$

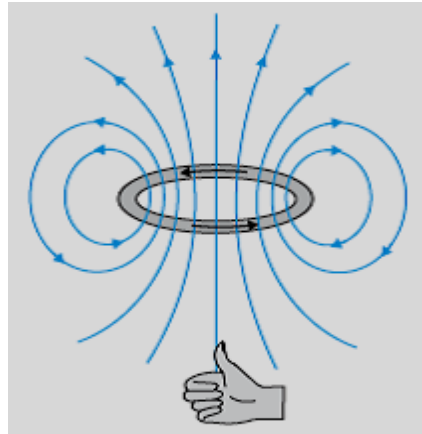

(b) Let current I be divided at point M into two parts I_1 and I_2 ; in bigger and smaller parts of the loop respectively.

Magnetic field of current I_1 at point O

$$\vec{B}_1 = \frac{\mu_0 I_1}{2R} \times \frac{1}{4} \otimes$$

Magnetic field of current I_2 at point O

$$\vec{B}_2 = \frac{\mu_0 I_2}{2R} \times \frac{3}{4} \odot$$

Net magnetic field $\vec{B} = \vec{B}_1 + \vec{B}_2$

$$|\vec{B}| = \frac{\mu_0 I_1}{8R} - \frac{\mu_0 I_2}{8R} \quad \text{--- (1)}$$

But $I_1 = 3I_2$ (As resistance of bigger part is three times that of the smaller part of the loop.)

Substituting $I_1 = 3I_2$ in equation (1)

$$\Rightarrow |\vec{B}| = 0$$

OR

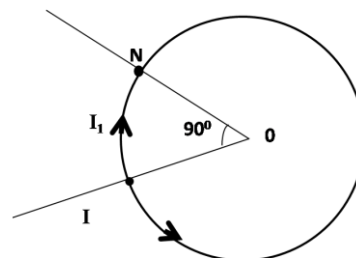

- | | |
|--|---|
| (a) Derivation of expression of magnetic field inside solenoid | 3 |
| (b) Finding the magnitude and direction of Magnetic field | 2 |

Any surface carrying current can be divided into small line elements, each of length ' dl '. Considering the tangential components of the magnetic field and finding $\vec{B} \cdot d\vec{l}$, sum of all elements tends to the integral, which can be expressed in the following form. : $\oint \vec{B} \cdot d\vec{l} = \mu_0 i$, This form is known as Ampers's circuital law.

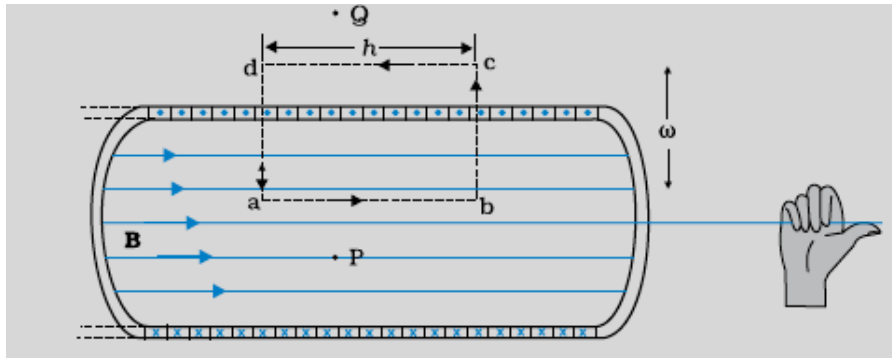

Let ' n ' be the number of turns per unit length. Then total number of turns in the length ' h ' is nh .

Hence, total enclosed current = nhI

Using Ampere's circuital law

$$\oint \vec{B} \cdot d\vec{l} = \mu_0 nhI$$

$$Bh = \mu_0 nhI$$

$$B = \mu_0 nI$$

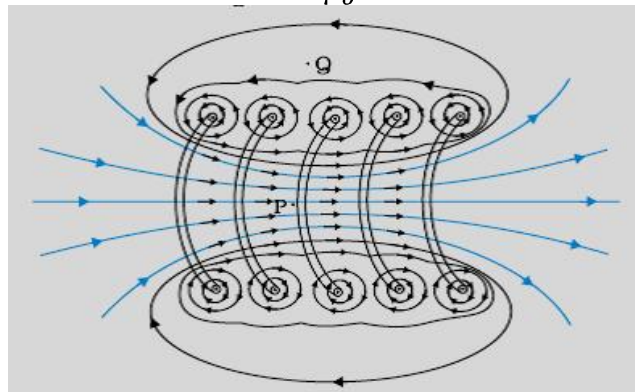

(b)

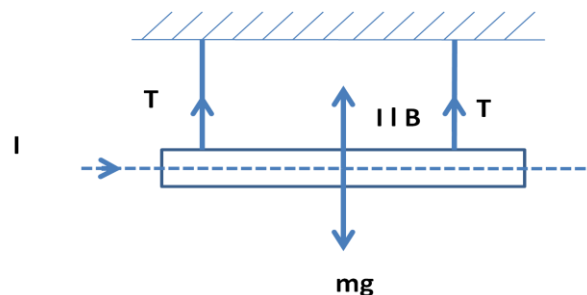

$$7.7 \times 1.6 \times 10^{-13} = \frac{9 \times 10^9 \times 2 \times 2.56 \times 10^{-38} \times 80}{r_o}$$

$$r_o = \frac{9 \times 10^9 \times 2 \times 2.56 \times 10^{-38} \times 80}{7.7 \times 1.6 \times 10^{-13}} \text{ m}$$

$$= 299 \times 10^{-16} \text{ m}$$

$$= 29.9 \times 10^{-15} \text{ m} \approx 30 \times 10^{-15} \text{ m}$$

OR

(a) Two important limitations of Rutherford model	1/2 + 1/2
Explanation of these limitations in Bohr's model	1/2 + 1/2
Calculation of wavelength of the H _α line	1
(b) Derivation of the expression for the radius of the n th orbit.	2

(a) (i) Electron moving in a circular orbit around the nucleus would get accelerated, therefore it would spiral into the nucleus, as it loses its energy.

(ii) It must emit a continuous spectrum.

According to Bohr's model of hydrogen atom,

(i) Electron in an atom can revolve in certain stable orbits without the emission of radiant energy.

(ii) Energy is released /absorbed only, when an electron jumps from one stable orbit to another stable orbit. This results in a discrete spectrum.

$$\frac{1}{\lambda} = R \left(\frac{1}{2^2} - \frac{1}{3^2} \right)$$

$$\frac{1}{\lambda} = 1.1 \times 10^7 \left(\frac{1}{4} - \frac{1}{9} \right)$$

$$\lambda = 656.3 \text{ nm}$$

(b) We have $\frac{mv^2}{r_n} = \frac{1}{4\pi\epsilon_0} \cdot \frac{e^2}{r_n^2}$

$$\Rightarrow r_n = \frac{e^2}{4\pi\epsilon_0 v_n^2} \text{ -----(1)}$$

From Bohr's Postulates:

$$mv_n r_n = \frac{nh}{2\pi}$$

$$v_n = \frac{nh}{2\pi m r_n}$$

Substituting for v_n , in equation (1), we get

$$r_n = \frac{\epsilon_0 n^2 h^2}{\pi m e^2}$$

1/2

1/2

5

1/2

1/2

1/2

1/2

1/2

1/2

1/2

1/2

1

5

Set1,Q26
Set2,Q25
Set3,Q24

(a) Naming the device and working with proper circuit	2
Derivation of expression for voltage gain and power gain	1 ½
(b) Drawing of transfer characteristics	1
Region used for amplifier	½

(a) Common emitter amplifier

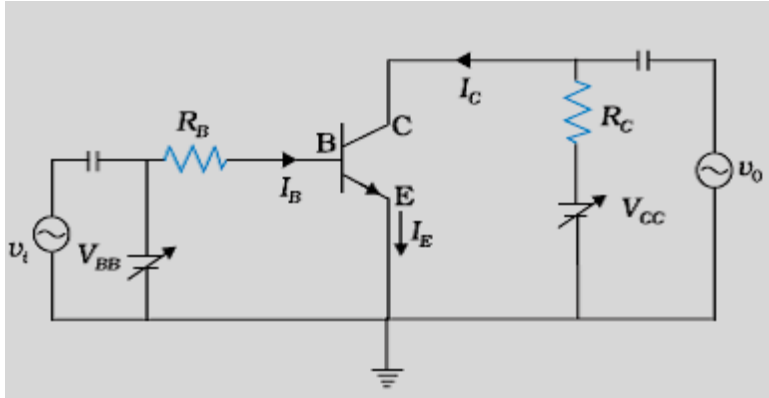

When the sinusoidal voltage is applied on the emitter base circuit, it gets amplified and its phase is reversed.

Input sinusoidal voltage:

$$v_i = \Delta I_B (R_B + r_i) = \Delta I_B r$$

$$\text{Also } \beta_{ac} = \frac{\Delta I_C}{\Delta I_B} \Rightarrow \Delta I_C = \beta_{ac} \Delta I_B$$

$$\Delta V_{CE} = -R_L \Delta I_C = -R_L \beta_{ac} \Delta I_B = v_o$$

$$\therefore \text{Voltage gain } A_v = \frac{v_o}{v_i} = -\beta_{ac} \frac{R_L}{r}$$

$$\begin{aligned} \text{Power gain } A_p &= \beta_{ac} A_v \\ &= \beta_{ac}^2 \frac{R_L}{r} \end{aligned}$$

(b)

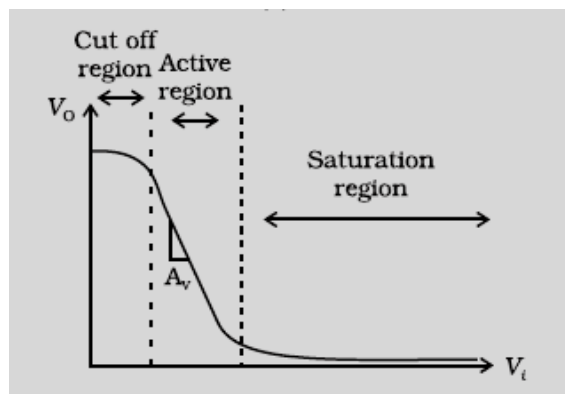

Transistor acts as an amplifier in the Active Region

OR

½

1

½

½

½

½

1

½

5



(a) Brief explanation of working of full wave rectifier	2
Drawing of input and output wave forms	1
(b) Identification of Logic gate	1
Truth table	

a)

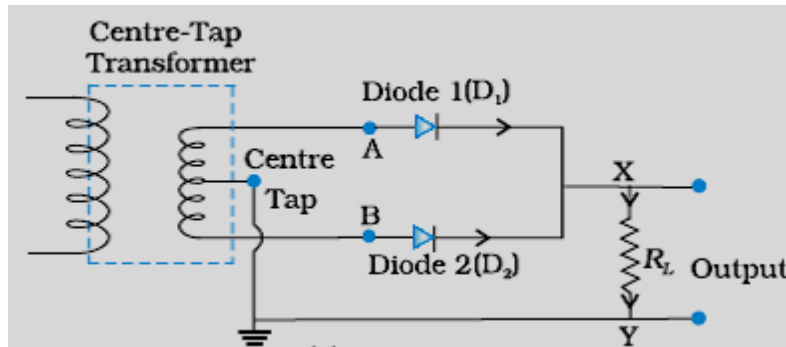

For half cycle of input ac, one diode out of the two, will get forward biased and will conduct, while the other diode, being reverse biased, will not conduct. For other cycle of input signal, the diode, which was reverse biased, will get forward biased and will conduct, and the other diode will get reverse biased and will stop conducting. Hence we obtain a unidirectional output voltage for the positive as well as for negative half cycles.

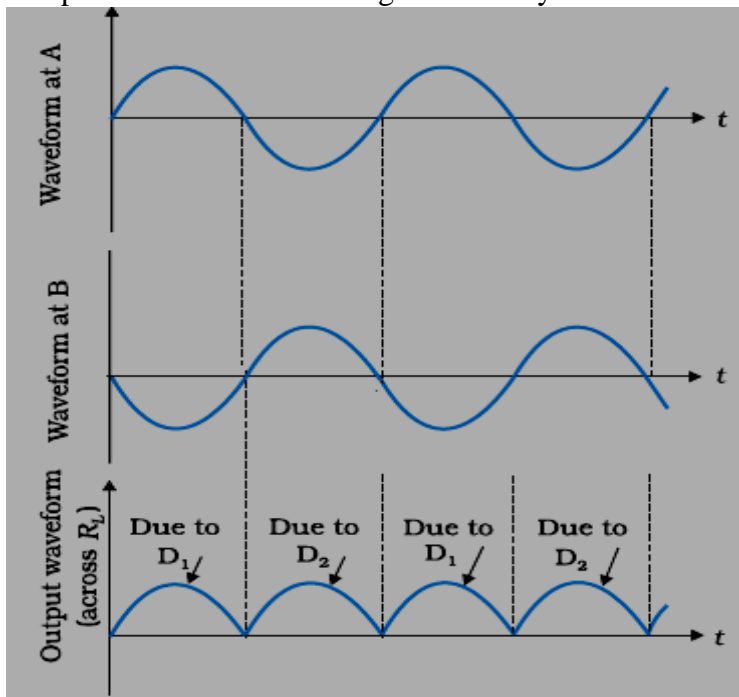

(b) Identification: AND Gate
Truth Table:

Input		Output
A	B	Y
0	0	0
0	1	0
1	0	0
1	1	1

